

LOC	DIST	REVISIONS			
GP	00	REV	DATE	BY	APPV
Y		REVISED PER ECO-08-007327	08APR08	BM	WM

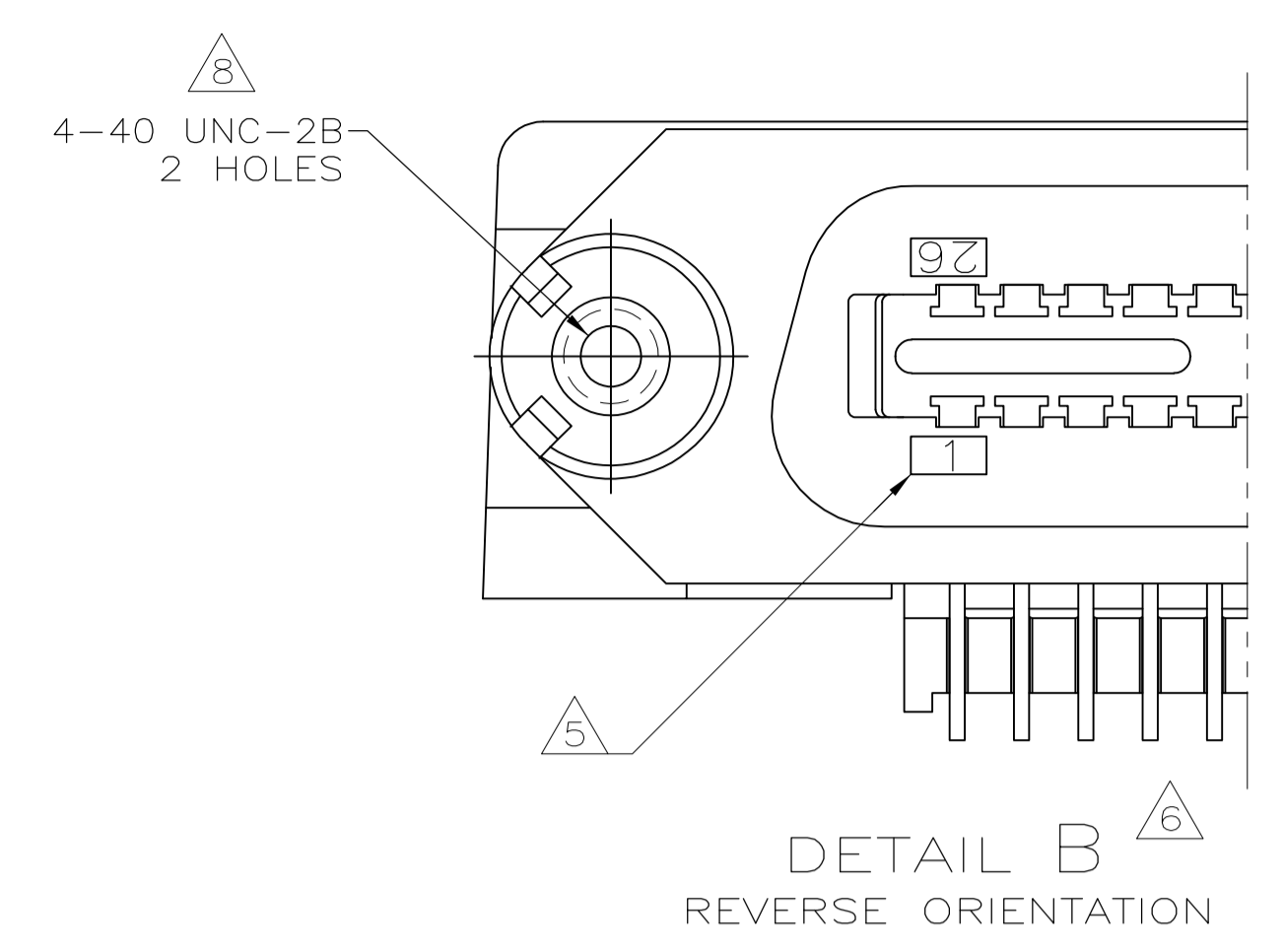

- 1 MATERIAL: HOUSING, BRACKET, PLATE AND COMB - THERMOPLASTIC, BLACK, 94V-0 RATED. TERMINALS - HIGH STRENGTH COPPER ALLOY PLATED WITH EITHER 0.76µm[.000030] MIN GOLD PLATE OR GOLD FLASH OVER PALLADIUM NICKEL PLATE, 0.76µm[.000030] MIN TOTAL ON MATING SURFACE. 3.05µm[.000120] MIN TIN-LEAD PLATE ON TAILS. ALL OVER 1.27µm[.000050] MIN NICKEL UNDERPLATE OVER ENTIRE TERMINAL. INSERT - #4-40 UNC, BRIGHT ZINC PLATED BRASS.
- 2 TERMINAL 1 IS LOCATED IN THIS ROW FOR STANDARD ORIENTATION, 552725-1, -2 AND -5.
- 3 TERMINAL SUPPORT PLATE CLEARANCE FOR TERMINAL STRAIN RELIEF AND FLUX REMOVAL.
- 4 MAXIMUM PANEL THICKNESS: 1.57 [.062].
- 5 TERMINAL 1 IS LOCATED IN THIS ROW FOR REVERSE ORIENTATION, 552725-3 AND -6 ONLY.
- 6 DETAILS "A" AND "B" ARE VIEWED FROM MATING SIDE OF RECEPTACLE ASSEMBLY.
- 7 FOR USE WITH A NO.4 BT TYPE SELF-TAPPING SCREW.
- 8 552725-1,-2 AND -3 ARE TAPPED 4-40; -5 AND -6 USE 4-40 THREADED INSERTS.
- 9 INSERT SHALL WITHSTAND 8 INCH-POUNDS OF TORQUE WITHOUT CRACKING HOUSING OR LOOSENING.

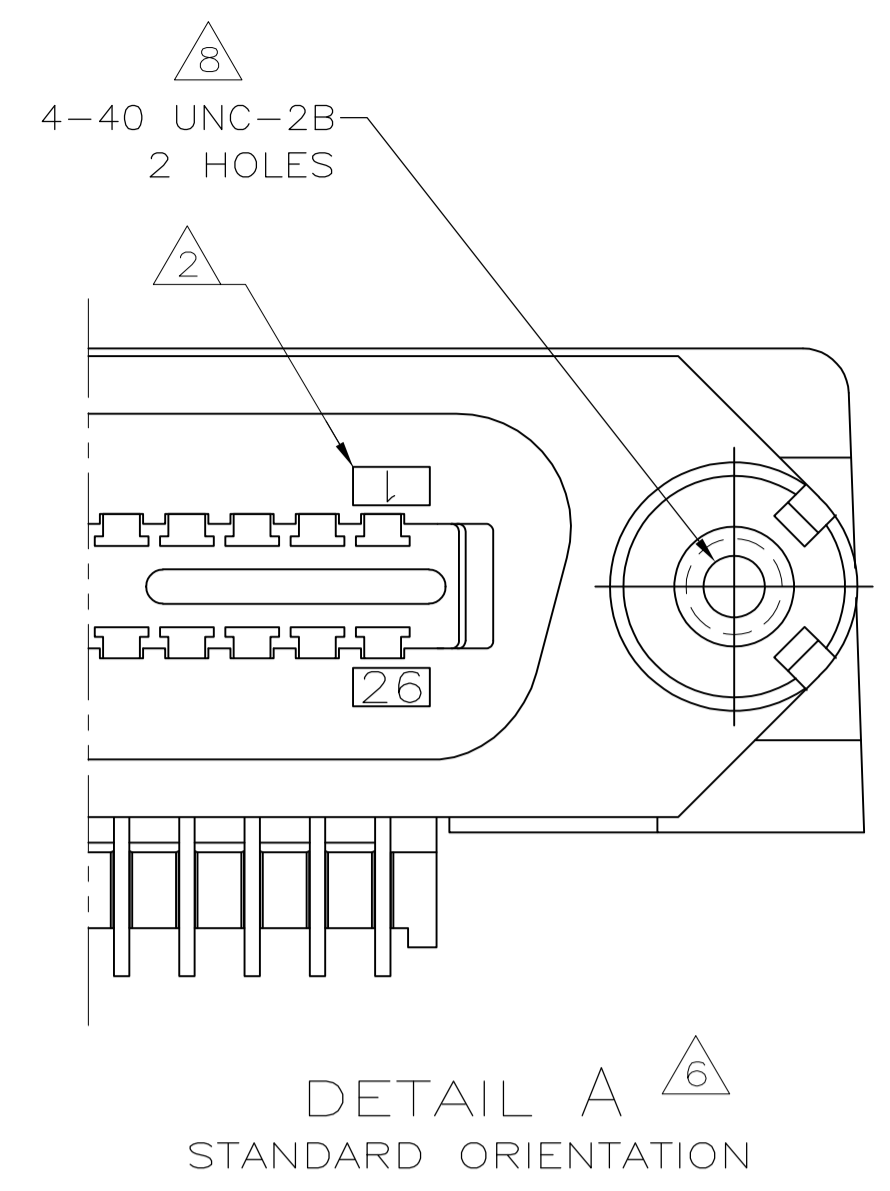
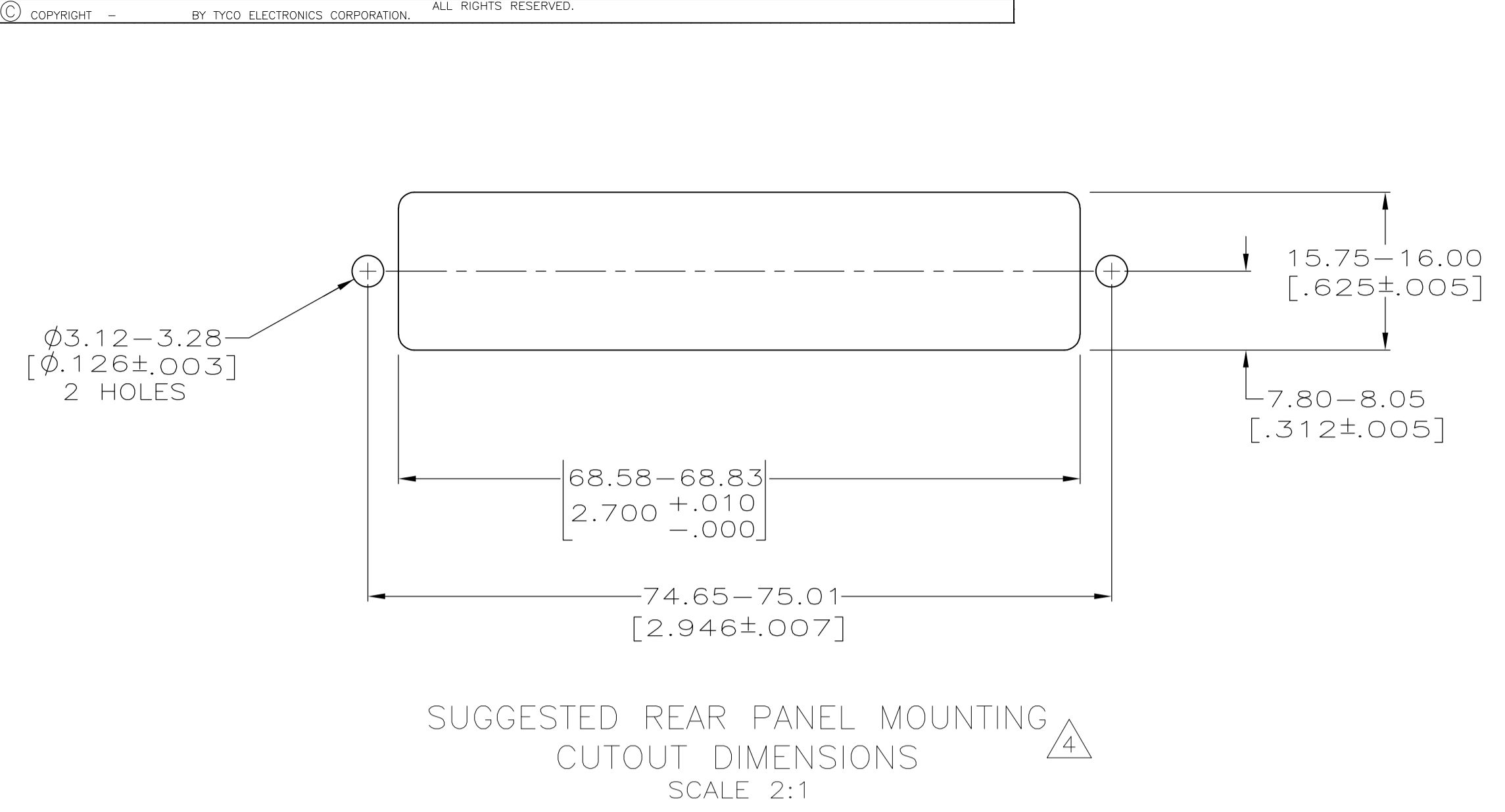
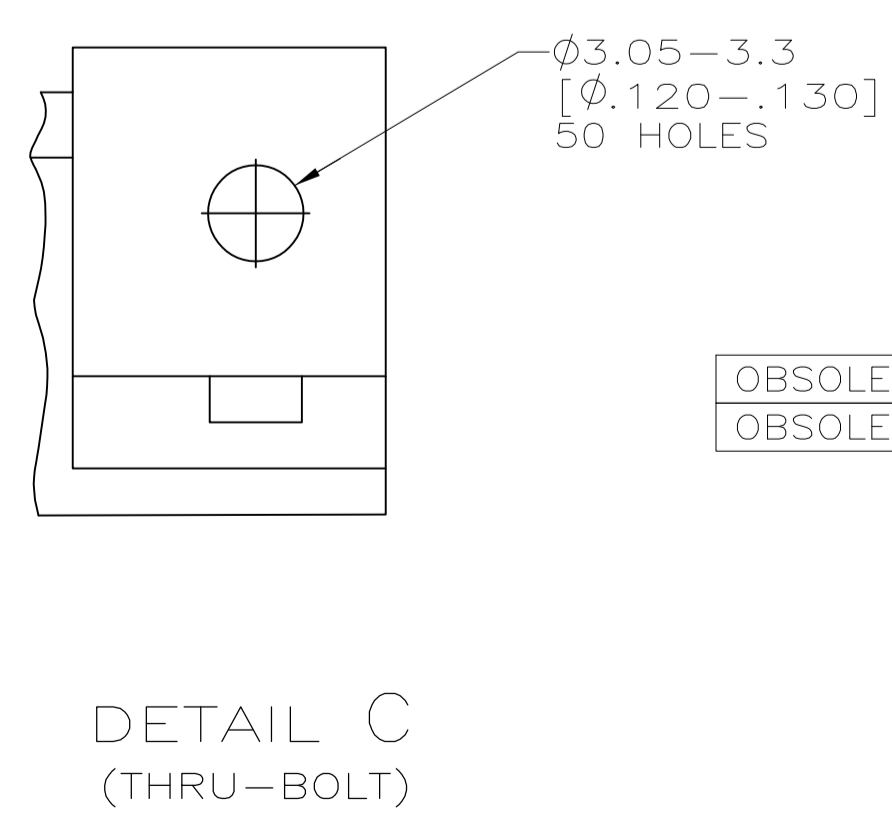
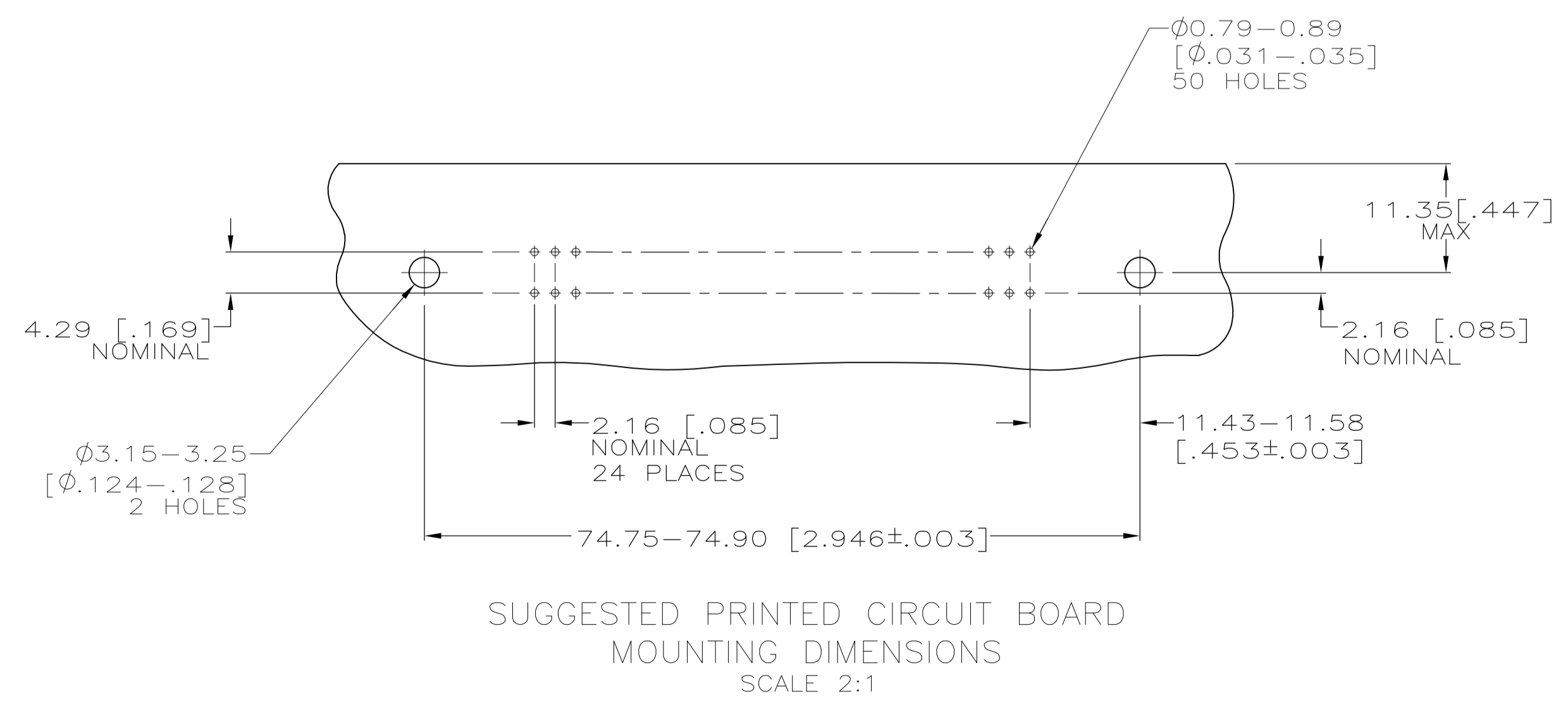
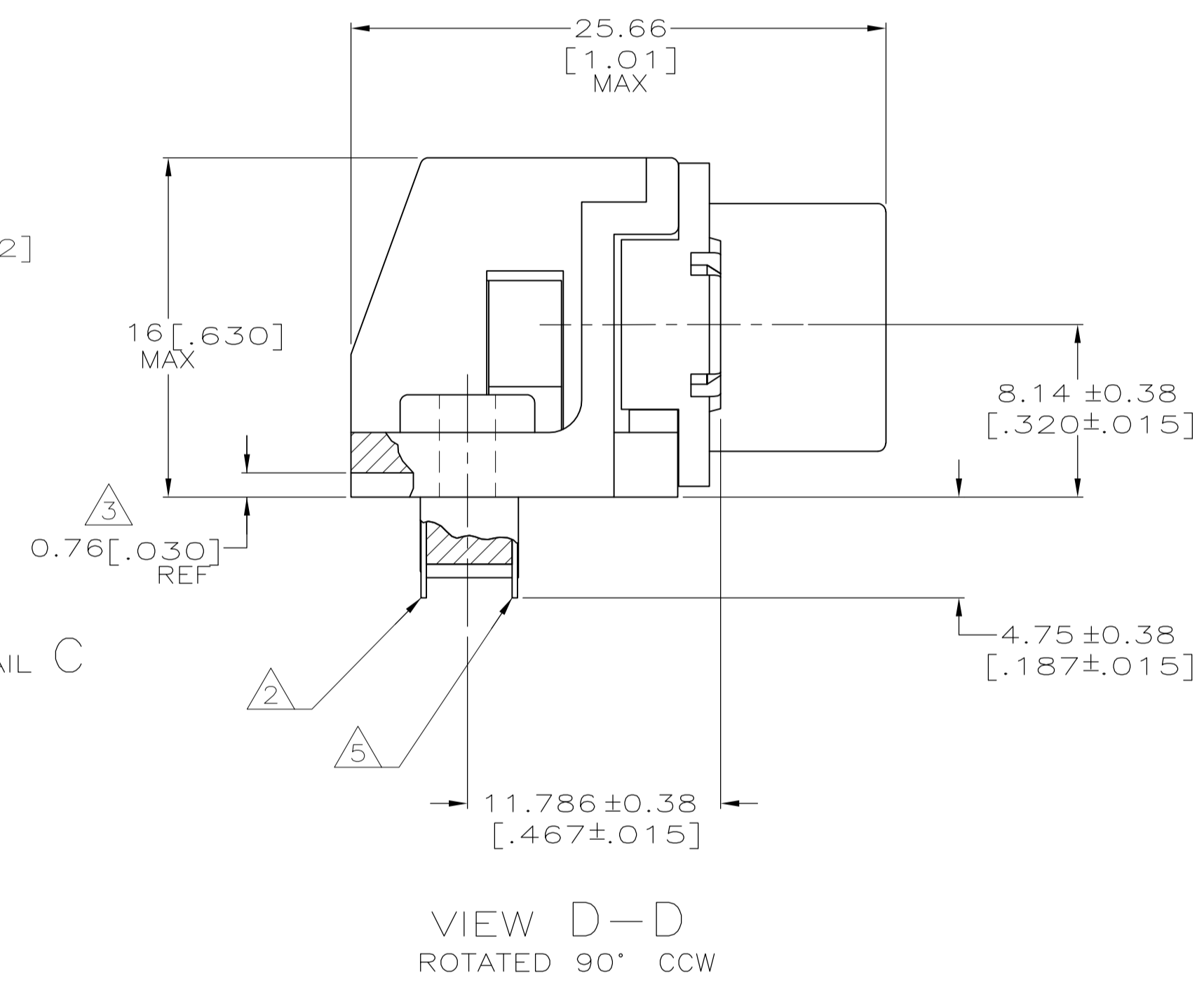
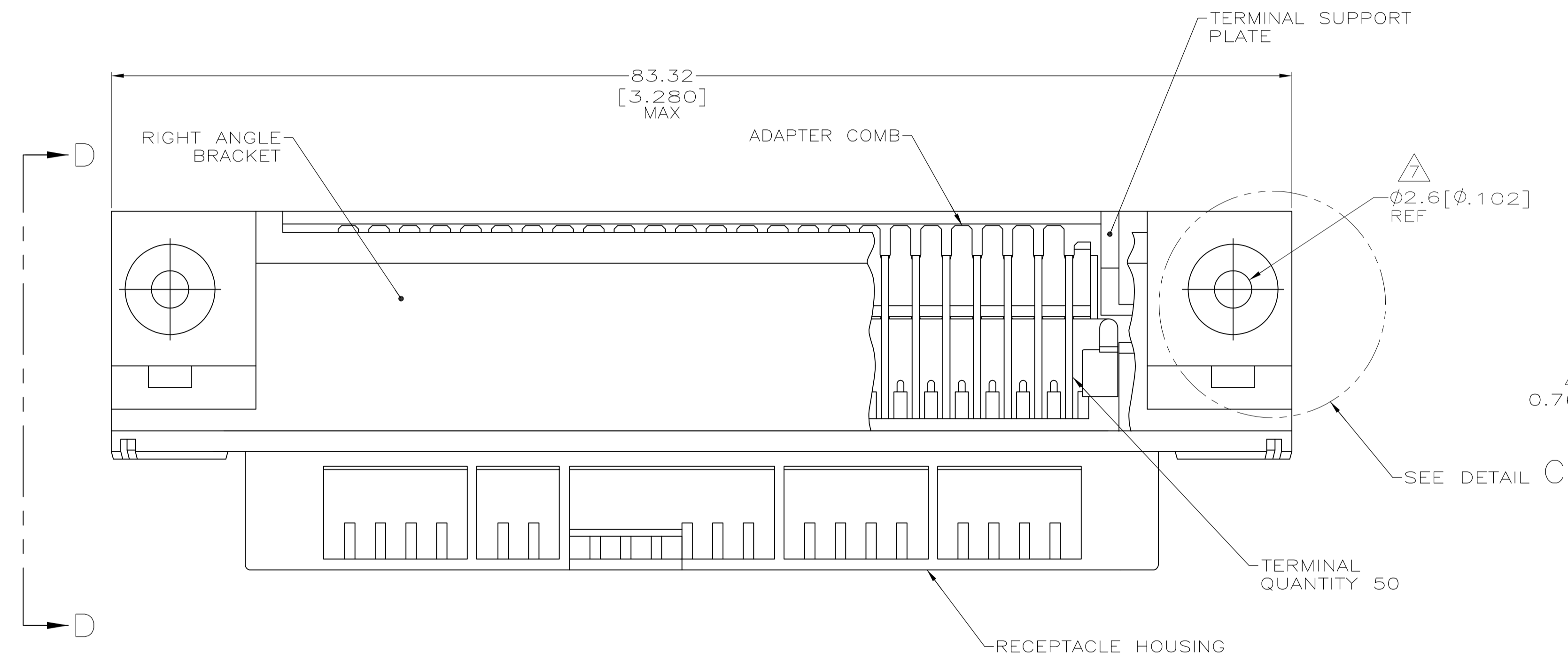

OBSELETE	8	9	THREADED INSERT	7	SELF-TAPPING	SEE DETAIL B	5	552725-6
OBSELETE	8	9	THREADED INSERT	7	SELF-TAPPING	SEE DETAIL A	2	552725-5
			TAPPED HOLE	8	SELF-TAPPING	SEE DETAIL B	5	552725-3
			TAPPED HOLE	8	THRU-BOLT(SEE DETAIL C)	SEE DETAIL A	2	552725-2
			TAPPED HOLE	8	SELF-TAPPING	SEE DETAIL A	2	552725-1
			THREAD TYPE		TYPE OF MOUNTING	DESCRIPTION		PART NUMBER

THIS DRAWING IS A CONTROLLED DOCUMENT.		DL DRUMMOND 18 AUG 97	Tyco Electronics Corporation Harrisburg, PA 17105-3608	
DIMENSIONS: mm [INCHES]		DL DRUMMOND 25 AUG 97	NAME: RECEPTACLE ASSEMBLY, 50 POSITION, RIGHT ANGLE, SELF TAPPING, CHAMP	
TOLERANCES UNLESS OTHERWISE SPECIFIED:		R FLAHERTY 25 AUG 97	PRODUCT SPEC	
0 PLC	± -	APPLICATION SPEC		
1 PLC	± -	SIZE: A1		
2 PLC	± -	CASE CODE: 00779		
3 PLC	± 0.13 [.005]	DRAWING NO: 552725		
4 PLC	± -	WEIGHT: -		
ANGLES	± -	CUSTOMER DRAWING		
MATERIAL	1	SCALE: 4:1 SHEET 1 of 1 REV Y		